

**FELICIA COPPER  
CONDUCTOR HEAD**

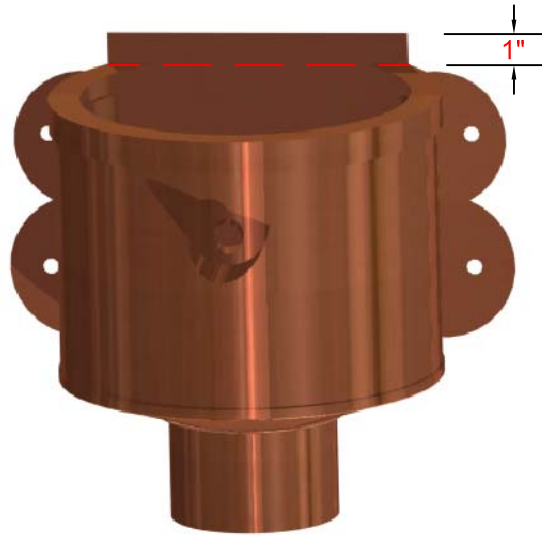

**MATERIAL:**

- COPPER [ ]16 [ ]20
- LEAD COATED COPPER 16
- EVERGREEN COPPER 16

**DIMENSION:**

- STANDARD 3" OUTLET

FOR THE CUSTOM SIZE, GO TO THE NEXT PAGE TO SPECIFY YOUR DESIRE DIMENSIONS!!!

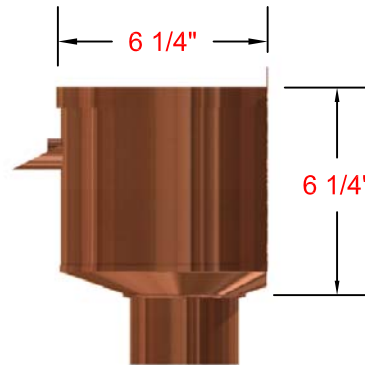
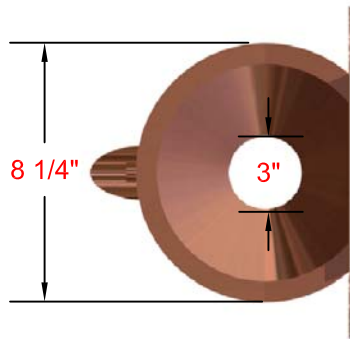

ONCE THE FABRICATION BEGINS, ITEMS CAN NOT BE RETURNED. THE DETAILS FOR THIS JOB WERE CHECKED AND APPROVED BY: \_\_\_\_\_

B & B SALES REP

NAME: \_\_\_\_\_ SIGN: X \_\_\_\_\_

DATE: \_\_ / \_\_ / \_\_



25-40 50 TH AVE.  
LIC, NY 11101  
P 718 433 2501  
F 718 433 2709  
info@bbsheetmetal.com  
www.bbsheetmetal.com

COMPANY:	DATE:
INVOICE: _____ PO#: _____	DRAWING #: L.H./C.H.-04
PROJECT:	PAGE(S): 1 OF 2
INSTALLATION INSTRUCTION:	DRAWING BY: NELSON SUT HO
OTHER:	APPROVED BY: BOBBY BASCHNAGEL

**FELICIA COPPER  
CONDUCTOR HEAD**

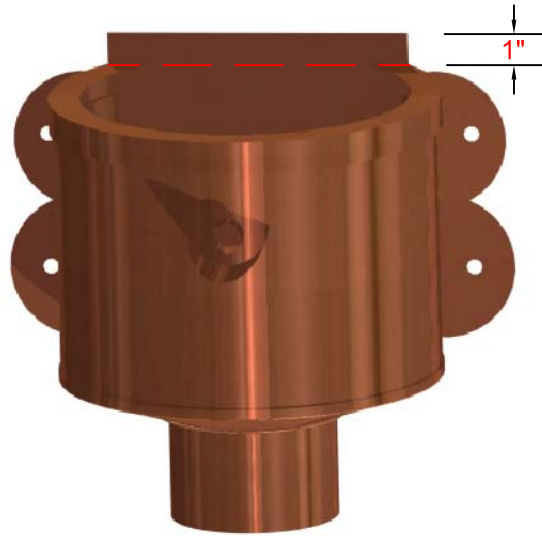

**MATERIAL:**

- COPPER [ ]16 [ ]20
- LEAD COATED COPPER 16
- EVERGREEN COPPER 16

**DIMENSION:**

- OUTLET
- WIDTH
- LENGTH
- HEIGHT

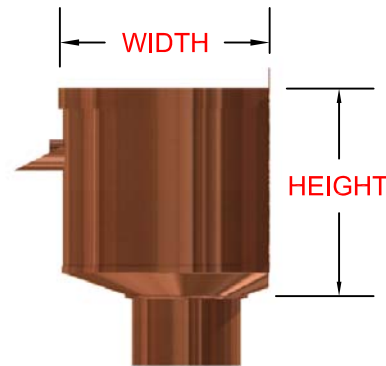
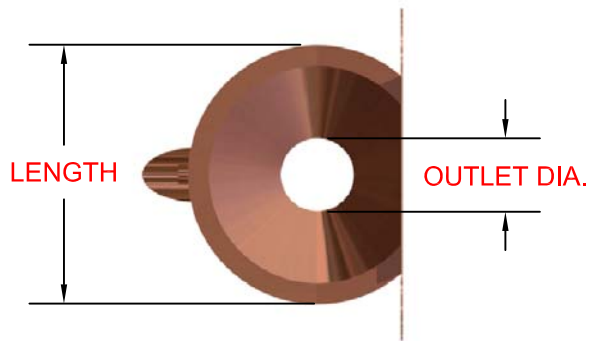

ONCE THE FABRICATION BEGINS, ITEMS CAN NOT BE RETURNED. THE DETAILS FOR THIS JOB WERE CHECKED AND APPROVED BY: \_\_\_\_\_

B & B SALES REP

NAME: \_\_\_\_\_ SIGN: X \_\_\_\_\_

DATE: \_\_/\_\_/\_\_



25-40 50 TH AVE.  
LIC, NY 11101  
P 718 433 2501  
F 718 433 2709  
info@bbsheetmetal.com  
www.bbsheetmetal.com

COMPANY:	DATE:
INVOICE: _____ PO#: _____	DRAWING #: _____
PROJECT:	L.H./C.H.-04
INSTALLATION INSTRUCTION:	PAGE(S): _____
OTHER:	2 OF 2
	DRAWING BY: _____
	NELSON SUT HO
	APPROVED BY: _____
	BOBBY BASCHNAGEL